

ADAM-6000 Series

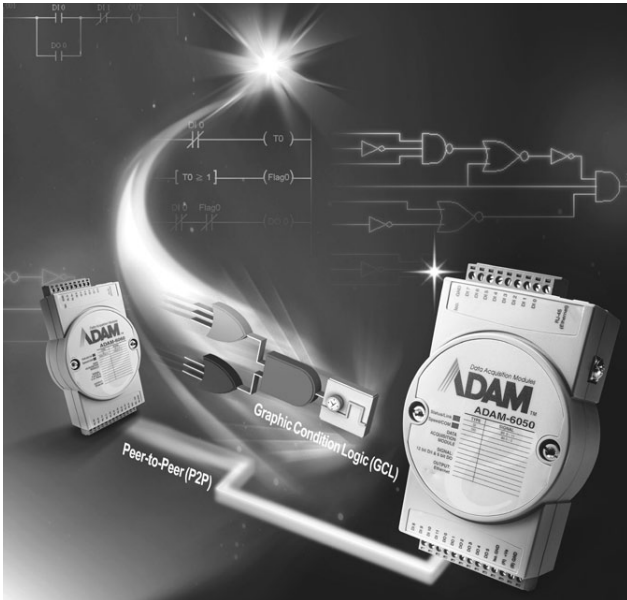

Features

- Ethernet-based smart I/O
- Mixed I/O in single module
- Pre-built HTTP server and web pages in each module
- Active I/O message by data stream or event trigger function
- Industrial Modbus/TCP protocol
- Easily update firmware through Ethernet
- ADAM.NET Class Library for .NET application
- Intelligent control ability by Peer-to-Peer and GCL function

The Path to Seamless Integration

The integration of automation and enterprise systems require a change in the architecture of open control systems. From Advantech's point of view, the level of integration between automation and enterprise systems can only be accomplished through Internet technology.

The key element of the seamless integration is a common network architecture, which breaks the traditional layers (enterprise layer, plant information layer, control layer, device level layer, and sensor layer) that require a data gateway as an interface to communicate between different layers. Industrial Ethernet is regarded as the most appropriate network to accomplish the task in industrial automation.

It is believed that IP/Ethernet protocols will progress beyond the control layer, into the field layers. Placing remote I/O with IP/Ethernet connections on the shop floor is economical. Advantech believes that over the next five years, Internet protocols over Ethernet will dominate major field connections. The Advantech ADAM-6000 series offers ideal remote I/O solutions with Internet protocols for industrial automation environments.

Control Strategy Moves to Field Devices

It is a trend to move I/O to remote locations to reduce wiring costs. Remote I/O is becoming smarter and equipped with control functions as they move from today's 16 to 64 I/O multiplexers to the smallest remote I/O units, with perhaps as few as four I/O in the near future.

The ADAM-6000 series is designed to realize the concept of the smart I/O blocks. With built-in GCL logic function, the ADAM-6000 series is a revolutionary smart I/O module close to the sensor layer in automation.

ADAM 6000: Smart, Web and Mixed Ethernet I/O Solutions

The integration of automation and enterprise systems and the adoption of an E-manufacturing strategy requires a shift in the manufacturing system architecture. E-manufacturing demands open access to real-time production data from the field. To achieve a seamless level of integration between plant floors and the enterprise level, some fundamental changes have to occur in I/O systems. E-manufacturing means the power of the Internet and I/O systems are used to take things one step further by leveraging Internet

technology. These revolutionary I/O systems are web-enabled, smart and are "just-fit" mixed I/O modules. Improvement of the PLC has been gradually moving from logic and I/O in a single chassis, to I/Os in remote locations. The ADAM-6000 series is based on the concept described above.

Why Smart I/O ?

To meet the requirements of future automation, smart I/O blocks have become popular in I/O system design. To implement the smart I/O blocks concept, I/O systems should be placed as close to the field sensors as possible. Therefore, intelligent control algorithms or basic mathematical functions are essential in I/O systems. ADAM-6000 provides intelligent functions that accelerate future automation development.

Why Web I/O ?

The Internet is the major technology that allows all levels of an organization to be able to communicate and make the sensor-to-boardroom model a reality. Access can be realized from any device that utilizes a standard web browser, so connections between remote manufacturing plants, production planners, plant managers, and the CEO can be made without a dedicated proprietary network. Since a web page can be installed in the I/O system as a Web I/O, then not only a sensor-to-boardroom model can be practiced, but sensor-to-home, and a sensor-to-mobile display can also be realized. ADAM-6000 Ethernet I/O modules provide built-in standard and customizable web pages, which truly demonstrate the power of Web I/O.

Why Mixed I/O ?

The impact of a tailor-made business model is spreading in automation, and I/O design is no exception. Over the past few years, the average size of PLCs have been reduced by the use of many small and micro PLCs to replace larger PLCs. A compact-sized and application-oriented mixed I/O is the trend. A just-fit mixed I/O module reduces the engineering effort, as well as installation and maintenance cost. It simplifies system architecture and increases system reliability. Obviously the ADAM-6000 series is the perfect choice to meet the specific requirements of many vertical markets.

Web-enabled Technology Becomes Popular on Factory Floors

As Internet technologies and standards have rapidly developed over the past decade, Web-based control methodologies now obviously represent a powerful opportunity for extending efficient network-based management techniques to encompass non-IT real-world assets.

The ADAM-6000 series is equipped with a built-in web server so that its data can be viewed, anytime-anywhere via the Internet. Moreover, ADAM-6000 series allows users to configure user-defined web pages to meet the diverse needs in various applications. With this powerful function, the ADAM-6000 series breaks the boundary of traditional multi-layer automation architecture and allows users to access field data directly in real time, which enables seamless integration between the plant floor and the front office.

HMI has provided a friendly operator interface for discrete control and sharply reduced the cost and complexity of automation systems. A web server has been added to most HMI software and a browser allows access to HMI displays from remote locations via the network. The end user is able to see and use an identical HMI from any Internet connected computer anytime, anywhere. ADAM-6000 series can be fully integrated with standard HMI software which supports Modbus/TCP.

Based on the Modbus/TCP standard, the ADAM-6000 firmware has a built-in Modbus/TCP server. Advantech provides the necessary ADAM .NET Utility, ADAM .NET class library and OPC Server for the ADAM-6000 series. You can configure this DA&C system via ADAM.NET Utility and integrate it with a HMI software package via Modbus/TCP driver or Modbus/TCP OPC Server. Furthermore, you can use the ADAM .NET class library to develop your own applications.

ADAM.NET Utility

ADAM.NET Utility is a user-friendly tool for system configuration. All ADAM-6000 I/O modules can be configured and tested through this easy-to-use graphical utility. With its powerful functionality, users can configure all related settings such as channel range, calibration, IP address, security, Peer-to-Peer and GCL.

ADAM.NET Class Library

Advantech offers ADAM .NET class library for programmers to develop applications in Microsoft Visual Studio .NET platform. ADAM .NET class library can dramatically reduce programmers development time since it provides a variety of functions including communications, data reading, data writing, hardware configuration, and more.

Software Support

How to Develop Applications

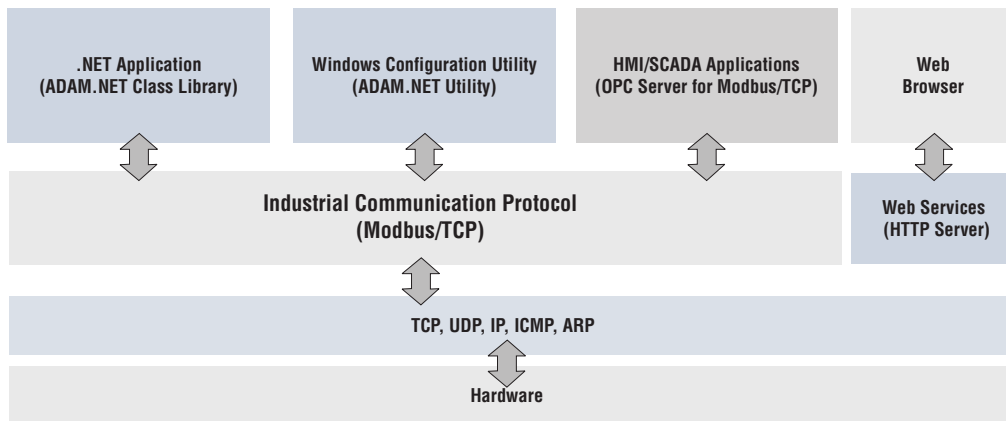

System Architecture

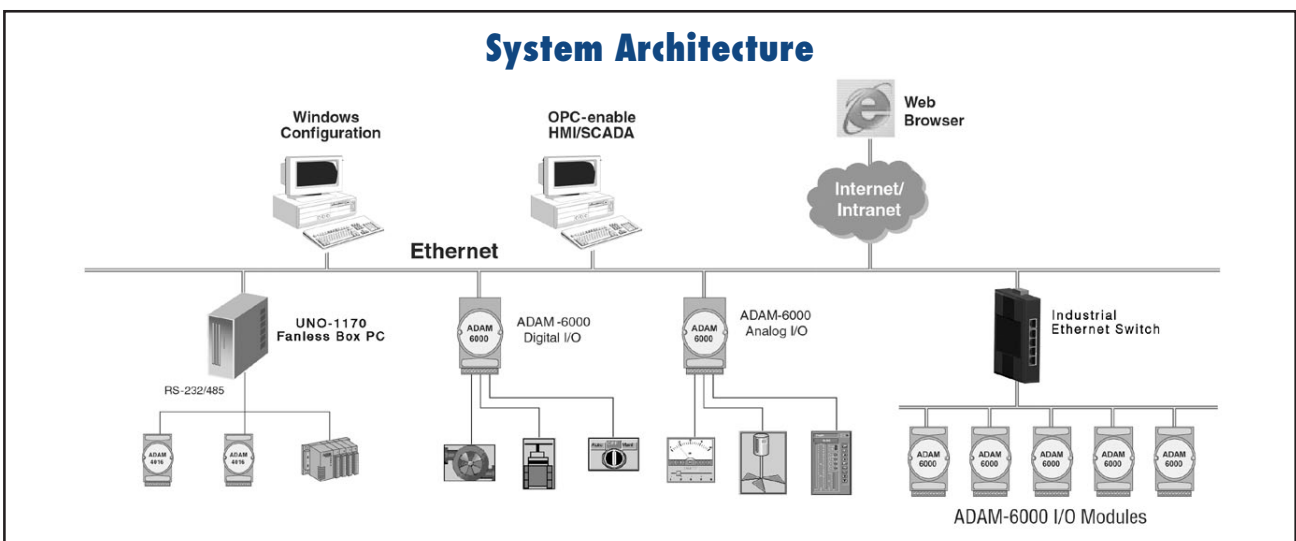

- 19 Embedded Controllers
- 20 PC-based Controllers
- 21 PAC
- 22 Motion Control
- 23 RS-485 I/O
- 24 Ethernet I/O
- 25 Building Automation
- 26 Self-service Terminals
- 27 eHome Platforms

ADAM-6000 Features: Peer-to-Peer

Requirements

One of our clients has three branches across multiple countries. For each branch, cameras were installed near the gates. At the headquarters, people in the control room can monitor each gate via Intranet. Now they want to enhance the system to remotely control each gate, so that each gate can be controlled from inside the control room of the headquarters. Since the distance between the headquarters and each branch is thousands of miles away, it may be very difficult to establish extra communication network for this purpose.

Solution

Through merely 3 pairs of Advantech ADAM-6000 Peer-to-Peer Ethernet I/O modules (without any other hardware), this application has been easily solved. For each pair of ADAM-6000 modules, one module is inside control room of headquarters, and another is located at each branch. When the module in headquarters is activated, it will notify its paired module at the branch to open or close the gate. The communication is Ethernet-based, so that our clients can leverage their existing Ethernet infrastructure.



What is Peer-to-Peer?

Unlike client / server mode, Peer-to-Peer enabled modules will actively update input channel status to specific output channel. There will be a pair of module: one input module and one output module. Users can define the mapping between input channel and output channel. Then the input value will be transferred to the output channel actively.

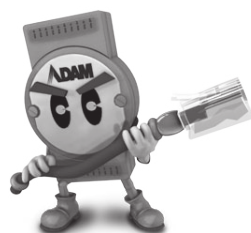

What Benefits Do Peer-to-Peer Modules Provide?

No Controller Required

For Ethernet I/O modules without Peer-to-Peer functionality, a controller is needed to read data from the input module and then send data to the output module. With Peer-to-Peer solutions, the controller can be removed since data will automatically transfer. This not only simplifies the process, but also helps save system hardware costs.

No Programming Required

To utilize Peer-to-Peer modules, the only thing required is to configure related setting through ADAM .NET Utility. No additional programming effort is needed, that it helps to save system development time.

Simple and Flexible System Wiring

Long distance wiring can easily become a nightmare. For some automation applications, if the PLC and the sensors are far away, one remote I/O module needs to be located near the sensors, and a proprietary communication network needs to connect the PLC and the remote I/O module, and the communications distance is severely limited. Moreover, networks provided by PLC manufacturers are rarely open. Peer-to-Peer modules can replace limited and closed networks with no limitations since they leverage the most open and flexible Ethernet networks.

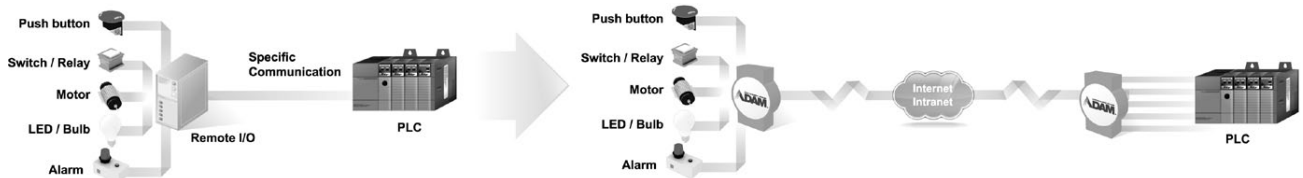

Why is Advantech's Peer-to-Peer Technology the Best Choice?

- Flexible Channel Mapping**
 ADAM-6000 Peer-to-Peer modules provide two modes: Basic and Advanced. For Basic mode, channels on one input module are directly mapped to channels on another single output module. For Advanced mode, channels on one input module can be mapped to channels on different output modules. (Refer to figure below)
- Fast Response Time**
 Advantech Peer-to-Peer modules feature excellent execution performance in market. The execution time to transfer data from input to output module is less than 1.2 millisecond.
- Advanced Security**
 When engineers use Peer-to-Peer modules, they don't want it to be controlled by non-authorized computers or devices. ADAM-6000 Peer-to-Peer module lets users decide which IP or MAC address has control authority. This can make sure the output module is only controlled by its paired input module.
- Advanced Reliability**
 When communication between a pair of ADAM-6000 Peer-to-Peer modules is broken, the digital output module can generate pre-defined value to ensure safety.

ADAM-6000 P2P Mode: Basic Mode

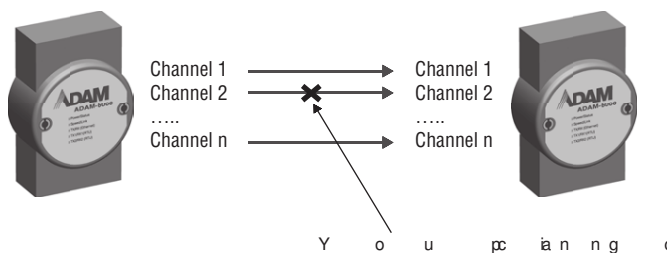

ADAM-6000 P2P Mode: Advanced Mode

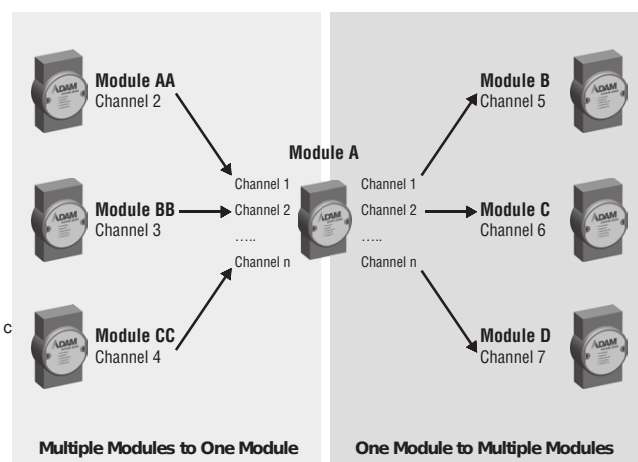

- 19 Embedded Controllers
- 20 PC-based Controllers
- 21 PAC
- 22 Motion Control
- 23 RS-485 I/O
- 24 Ethernet I/O
- 25 Building Automation
- 26 Self-service Terminals
- 27 eHome Platforms

ADAM-6000 Features: GCL

Using Ethernet I/O Modules as Controllers

What is GCL?

GCL (Graphic Condition Logic) gives Ethernet I/O modules control ability. Users can define the control logic rules using graphic configuration environment in ADAM.NET Utility, and download defined logic rules to ADAM-6000 Ethernet I/O modules. Then, that Ethernet I/O module will execute the logic rules automatically just like a standalone controller.

For each Ethernet I/O module, 16 logic rules can be defined. In the configuration environment of ADAM.NET Utility, 4 graphic icons shows the 4 stages of one logic rule: Input, Logic, Execution and Output (Refer to figure below). Users can simply click on each icon and one dialog window will pop-up for users to configure each stage. After completing all configurations, users can click one button to download the defined logic rules to the specific Ethernet I/O module.

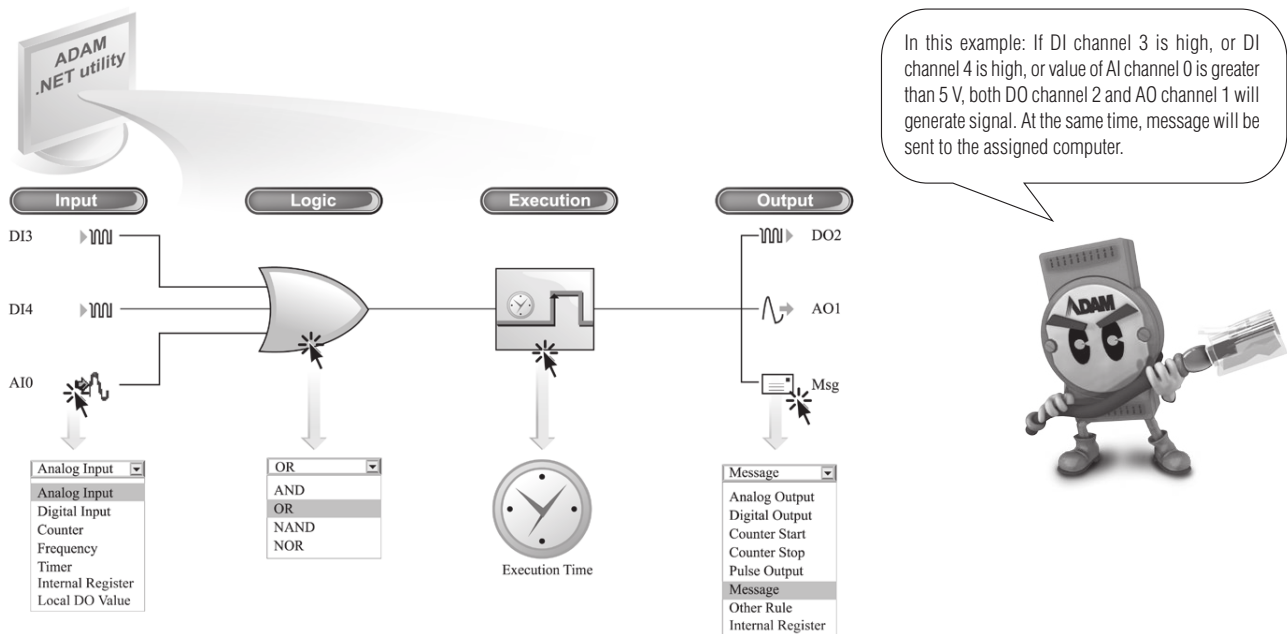

GCL Typical Application: Water Tank Control

Two ADAM-6000 modules are the only hardware used for this automation application, and no any other controller or computer is needed. Refer to Figure at right hand side. ADAM-6017 module is located on the rooftop, connecting with water level sensor to measure water level in the water tower. ADAM-6050 module is located in the basement, controlling the water pump. These two ADAM modules are connected by Ethernet, so no extra wiring is needed. They can leverage the existing Ethernet network in the building.

GCL is running on the ADAM-6017 module, continuously comparing the water level with specific limit value. If the water level is less than the limit value, it will trigger DO channel on ADAM-6050 module to start the pump to fulfill the water tank. There is no need to write any program and it takes less than 5 minutes to complete the configuration by the ADAM.NET Utility.

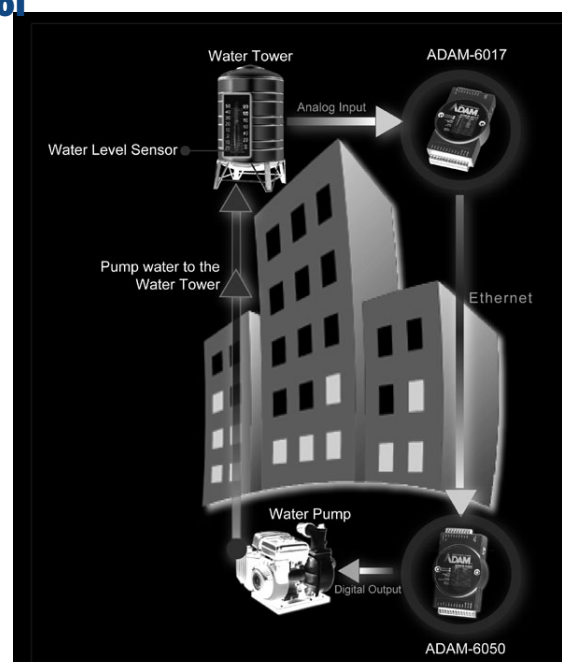

Graphic Condition Logic (GCL) Technology

ADAM-6000 GCL is the Simplest Logic Ethernet I/O

Complete Graphic Configuration Environment

Unlike other text-based logic configuration utility, Advantech GCL provides a complete graphic configuration utility, which is very intuitive to use. By simply clicking the icons, all related configurations can be done through the popup dialog window. GCL is not only easy-to-use, but is also features very powerful functionality.

Supports Both Local and Remote Output

When users defines the destination of Output stage (such as digital output, analog output, counter and pulse output), users can choose either local module or other remote module as target.

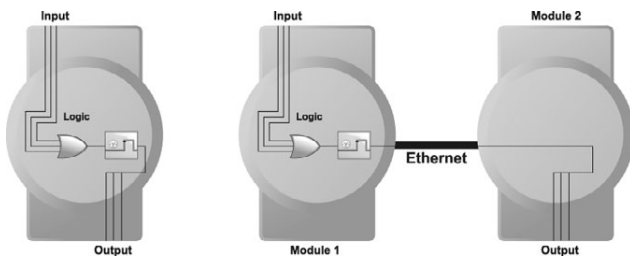

Cascade Logic

The output of one logic rule can be another rule. Therefore, different rules can be combined together. GCL provides this kind of functionality called Cascade Logic. It helps to create more input number of logic rule. For example, if users combine rule 1 and rule 2 with rule 3, the maximum inputs become 7 inputs. (Two inputs of rule 3 will be rule 1 and rule 2. Refer to figure below.) So users can define complex logic architecture to satisfy various application requirements.

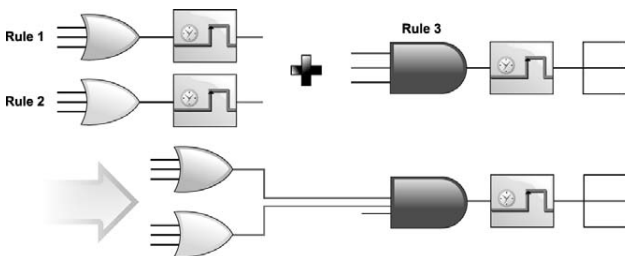

Distributed Cascade Logic

Users can assign other rule as output of one logic rule. In fact, that "Other Rule" can be on the same module, or on another remote module. So, one GCL logic architecture can operate across different modules. Several Ethernet I/O modules can be integrated into one complete logic system.

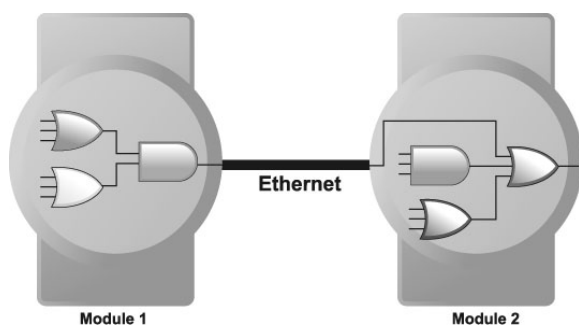

Feedback

Users can assign input and output of logic rule to the same internal register. This gives GCL feedback ability. No hardware wiring is needed.

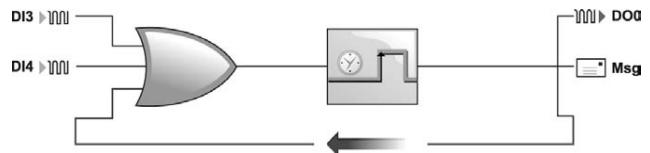

Rich I/O Options

Analog Input	Thermocouple, RTD, Voltage, Current
Analog Output	Voltage, Current
Digital Input	Dry Contact, Wet Contact, Counter/Frequency input
Digital Output	Sink, Source, Relay output, Pulse output

Fast Execution Time

Advantech GCL features extremely short logic rule execution time in the market. When users choose local output (input and output channel are on the same module), the processing time (including hardware input delay time, one logic rule execution time and hardware output delay time) is less than 1 millisecond. When users choose remote output (input and output channel are on different modules), the total time needed (including processing and communication time) is less than 3 milliseconds.

Analog Input Scaling

When configuring analog input condition, GCL provides linear scaling function to convert measured voltage/current value to its engineer unit value (such as temperature or pressure unit). Then users can use the engineer unit value to define the logic condition, and it is more intuitive for users.

Online Monitoring

After users complete all GCL configurations in ADAM.NET Utility, they can simply click the "Run Monitoring" button. Then users can see real-time execution workflow of logic rule on ADAM-6000 modules. Beside, current input values will also be displayed. This greatly helps users to maintain the system easily.

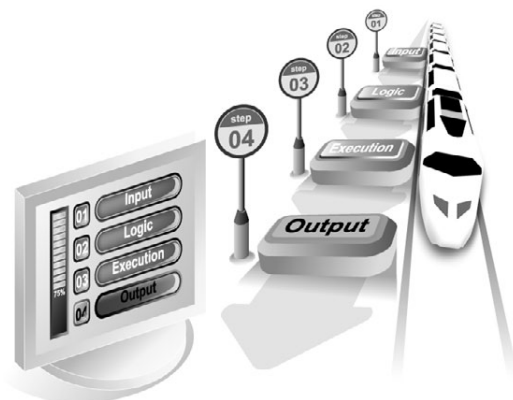

Sending Messages

In GCL, you can define your customized message. When conditions are satisfied, message, module's IP and I/O status will be sent to defined PC or device.

Local DO Status Can be Input Condition

In GCL, you can read the local DO channel value and use it in the input condition. So you can define logic rule based on the local DO status.

19
Embedded Controllers

20
PC-based Controllers

21
PAC

22
Motion Control

23
RS-485 I/O

24
Ethernet I/O

25
Building Automation

26
Self-service Terminals

27
eHome Platforms

ADAM-6000 Series Selection Guide



Spec.	ADAM-6024	ADAM-6024	ADAM-6024	ADAM-6024	ADAM-6024	
Interface	10/100 Mbps Ethernet					
Peer-to-Peer	Yes		No		Receiver Only ²	
GCL	Yes		No		Receiver Only ²	
Resolution	16 bit		16 bit for AI 12 bit for AO		16 bit for AI 12 bit for AO	
Analog	Channels	8	8	6	6	
	Sampling Rate	10 S/s				
	Voltage Range	±150 mV, ±500 mV, ±1 V, ±5 V, ±10 V		-	±10 V	±10 V
	Current Range	0 ~ 20 mA 4 ~ 20 mA		-	0 ~ 20 mA 4 ~ 20 mA	0 ~ 20 mA 4 ~ 20 mA
	Supported Sensors	Pt, Balco and Ni RTD		J, K, T, E, R, S, B Thermocouple	-	-
	Burn-in	Yes	-	Yes	-	-
Analog Output	Channels	-	-	2	2	
	Current Range	0 ~ 20 mA, 4 ~ 20 mA with 15 V _{DC}		0 ~ 20 mA, 4 ~ 20 mA with 15 V _{DC}	0 ~ 20 mA, 4 ~ 20 mA with 15 V _{DC}	
	Voltage Range	0 ~ 10 V _{DC} with 30 mA		0 ~ 10 V _{DC} with 30 mA	0 ~ 10 V _{DC} with 30 mA	
Digital	Input Channels	-	2 (Sink)	8 (Sink)	2 (Sink)	
	Outputs	2 (Sink)				
	Extraneous Inputs	-				
	Filtering	-				
	Pulse Width	-				
	High Speed / Low Impedance	Yes	Yes	Yes	-	-
Isolation	2,000 V _{DC}		2,000 V _{DC} ³		2,000 V _{DC} ³	
Remark	-	-	-	Built-in Dual Loop PID Control Algorithm		
Page	24-14	24-14	24-14	24-15	24-15	

Note 1: Peer-to-Peer and GCL cannot run simultaneously, only one feature is enabled at one time.

Note 2: ADAM-6024 can only act as a receiver and generate analog output when using Peer-to-Peer or GCL.

Note 3: Only for analog input and analog output channels.

Selection Guide



19
Embedded Controllers

20
PC-based Controllers

21
PAC

22
Motion Control

23
RS-485 I/O

24
Ethernet I/O

25
Building Automation

26
Self-service Terminals

27
eHome Platforms

S p e c .		M o A d D e l A	M D 6 A 0 M5 D 6 A 0 M5 D 6 A 0 M5 D 6 A 0 M5 D 6 A 0	M5 D 6 A 0 M5 D 6 A 0 M5 D 6 A 0 M5 D 6 A 0	M5 D 6 A 0 M5 D 6 A 0 M5 D 6 A 0 M5 D 6 A 0	
I n t e r f a c e		10/100 Mbps Ethernet				
P e e r - t o - P e e r		Yes				
G C L		Yes				
R e s o u r c e s		-				
A n a l o g	C h a n n e l s	-	-	-	-	-
	S a m p l i n g	-	-	-	-	-
	V o l t a g e I n p u t	-	-	-	-	-
	C o u r s e	-	-	-	-	-
	D i r e c t I n p u t	-	-	-	-	-
	S e n s o r I n p u t	-	-	-	-	-
	B u r n I n	-	-	-	-	-
A n a l o g	M a t h F u n c t i o n s	-	-	-	-	-
	C h a n n e l	-	-	-	-	-
	I C o g r o u p	-	-	-	-	-
D i g i t a l	V o l t a g e	-	-	-	-	-
	I n p u t C h a n n e l s	12	12	8	6	6
	O u t p u t	6 (Sink)	2 (Sink)	8 (Source)	6-channel relay	6-channel power relay
	E x t r a S o u r c e s	2	2	2	-	-
	I t a o u t	3 kHz	4.5 kHz	3 kHz	3 kHz	3 kHz
	F r e q u e n c y	3 kHz	4.5 kHz	3 kHz	3 kHz	3 kHz
	P u l s e	-	-	-	-	-
I s o l a t i o n	H i g h / L o w S i g n a l i n g	-	A l a r m	-	-	-
	I s o l a t i o n	-	-	2,000 V _{DC}	-	-
R e m a r k s		-	-	-	-	-
P a g e		24-16	24-16	24-16	24-17	24-17

Note 1: Peer-to-Peer and GCL cannot run simultaneously, only one feature is enabled at one time.

ADAM-6015

ADAM-6017

ADAM-6018

7-ch Isolated RTD Input Modbus TCP Module
8-ch Isolated Analog Input Modbus TCP Module with 2-ch DO
8-ch Isolated Thermocouple Input Modbus TCP Module with 8-ch DO



ADAM-6015



ADAM-6017



ADAM-6018



Specifications

Analog Input

- **Channels** 7 (differential)
- **Input Impedance** > 10 M Ω
- **Input Connections** 2 or 3 wire
- **Input Type** Pt, Balco and Ni RTD
- **RTD Types and Temperature Ranges**
 - Pt 100 -50° C ~ 150° C
 - 0° C ~ 100° C
 - 0° C ~ 200° C
 - 0° C ~ 400° C
 - 200° C ~ 200° C
 - Pt 1000 -40° C ~ 160° C
 - Supports both IEC 60751 ITS90 (0.03851 W/W/°C) and JIS C 1604 (0.03916 W/W/°C)
 - Balco 500 -30° C ~ 120° C
 - Ni 518 -80° C ~ 100° C
 - 0° C ~ 100° C
- **Accuracy** $\pm 0.1\%$ or better
- **Span Drift** ± 25 ppm/° C
- **Zero Drift** ± 6 μ V/° C
- **Wire Burn-out Detection**

Ordering Information

- **ADAM-6015** 7-ch Isolated RTD Input Modbus TCP Module

Specifications

Analog Input

- **Channels** 8 (differential)
- **Input Impedance** > 10 M Ω (voltage)
120 Ω (current)
- **Input Type** mV, V, mA
- **Input Range** ± 150 mV, ± 500 mV, ± 1 V
 ± 5 V, ± 10 V, 0-20 mA, 4-20 mA
- **Accuracy** $\pm 0.1\%$ or Better (voltage)
 $\pm 0.2\%$ or Better (current)
- **Span Drift** ± 25 ppm/° C
- **Zero Drift** ± 6 μ V/° C

Digital Output

- **Channels** 2, open collector to 30 V, 100 mA max. load
- **Power Dissipation** 300 mW for each module

Ordering Information

- **ADAM-6017** 8-ch Isolated AI with 2-ch DO Modbus TCP Module

Specifications

Analog Input

- **Channels** 8 (differential)
- **Input Impedance** > 10 M Ω
- **Input Type** Thermocouple
- **Thermocouple Type and Range:**
 - J 0 ~ 760° C
 - K 0 ~ 1,370° C
 - T -100 ~ 400° C
 - E 0 ~ 1,000° C
 - R 500 ~ 1,750° C
 - S 500 ~ 1,750° C
 - B 500 ~ 1,800° C
- **Accuracy** $\pm 0.1\%$ or Better
- **Span Drift** ± 25 ppm/° C
- **Zero Drift** ± 6 μ V/° C
- **Wire Burn-out Detection**

Digital Output

- **Channels** 8, open collector to 30 V, 100 mA max. load
- **Power Dissipation** 300 mW for each module

Ordering Information

- **ADAM-6018** 8-ch Isolated Thermocouple Input Modbus TCP Module w/ 8-ch DO

Common Specifications

General

- **LAN** 10/100Base-T(X)
- **Power Consumption** 2 W @ 24 V_{DC}
- **Connectors** 1 x RJ-45 (LAN), Plug-in screw terminal block (I/O and power)
- **Watchdog** System (1.6 second) and Communication (programmable)
- **Power Input** 10 ~ 30 V_{DC}
- **Supports Peer-to-Peer**

- **Supports GCL**
- **Supports Modbus/TCP, TCP/IP, UDP and HTTP Protocols**

Analog Input

- **Resolution** 16-bit
- **Sampling Rate** 10 sample/second (total)
- **CMR @ 50/60 Hz** 90 dB
- **NMR @ 50/60 Hz** 60 dB

Protection

- **Over Voltage Protection** ± 35 V_{DC}
- **Isolation Protection** 2,000 V_{DC}

- **Built-in TVS/ESD Protection**
- **Power Reversal Protection**

Environment

- **Operating Temperature** -10 ~ 70° C (14 ~ 158° F)
- **Storage Temperature** -20 ~ 80° C (-4 ~ 176° F)
- **Operating Humidity** 20 ~ 95% RH (non-condensing)
- **Storage Humidity** 0 ~ 95% RH (non-condensing)

ADAM-6022

ADAM-6024

Ethernet-based Dual-loop PID Controller

12-ch Isolated Universal Input/Output Modbus TCP Module



ADAM-6022



Specifications

General

- **Loop Number** 2 (3 AI, 1 AO, 1 DI, 1 DO for each control loop)

Analog Input

- **Channels** 6 (differential)
- **Input Range** $\pm 10 V_{DC}$, 0 ~ 20 mA, 4 ~ 20 mA

Analog Output

- **Channels** 2
- **Output Type** V, mA
- **Output Range** 0 ~ 10 V_{DC} , 4 ~ 20 mA, 0 ~ 20 mA

Digital Input

- **Channels** 2
- **Dry Contact** Logic level 0: close to GND
Logic level 1: open
- **Wet Contact** Logic level 0: 0 ~ 3 V_{DC}
Logic level 1: 10 ~ 30 V_{DC}

Digital Output

- **Channels** 2, open collector to 30 V, 100 mA max. load
- **Power Dissipation** 300 mW for each module

Ordering Information

- **ADAM-6022** Ethernet-based Dual-loop PID Controller



ADAM-6024



Specifications

Analog Input

- **Channels** 6 (differential)
- **Input Range** $\pm 10 V_{DC}$, 0 ~ 20 mA, 4 ~ 20 mA

Analog Output

- **Channels** 2
- **Output Type** V, mA
- **Output Range** 0 ~ 10 V_{DC} , 4 ~ 20 mA, 0 ~ 20 mA

Digital Input

- **Channels** 2
- **Dry Contact** Logic level 0: close to GND
Logic level 1: open
- **Wet Contact** Logic level 0: 0 ~ 3 V_{DC}
Logic level 1: 10 ~ 30 V_{DC}

Digital Output

- **Channels** 2, open collector to 30 V, 100 mA max. load
- **Power Dissipation** 300 mW for each module

Supports

- **Peer-to-Peer (Receiver only)**
- **GCL (Receiver only)**

Ordering Information

- **ADAM-6024** 12-ch Isolated Universal I/O Modbus TCP Module

19	Embedded Controllers
20	PC-based Controllers
21	PAC
22	Motion Control
23	RS-485 I/O
24	Ethernet I/O
25	Building Automation
26	Self-service Terminals
27	eHome Platforms

Common Specifications	
General	
▪ LAN	10/100Base-T(X)
▪ Power Consumption	4 W @ 24 V_{DC}
▪ Connectors	1 x RJ-45 (LAN), Plug-in screw terminal block (I/O and power)
▪ Watchdog	System (1.6 second) and Communication (programmable)
▪ Power Input	10 ~ 30 V_{DC}
▪ Supports Modbus/TCP, TCP/IP, UDP and HTTP Protocols	
Analog Input	
▪ Input Impedance	20 $M\Omega$
▪ Accuracy	$\pm 0.1\%$ of FSR
▪ Resolution	16-bit
▪ Sampling Rate	10 sample/second
▪ CMR @ 50/60 Hz	90 dB
▪ NMR @ 50/60 Hz	60 dB
▪ Span Drift	± 25 ppm/ $^{\circ}C$
▪ Zero Drift	± 6 $\mu V/^{\circ}C$
Analog Output	
▪ Accuracy	$\pm 0.1\%$ of FSR
▪ Resolution	12-bit
▪ Drift	± 50 ppm/ $^{\circ}C$
▪ Current Load Resistor	0 ~ 500 Ω
Protection	
▪ Isolation Protection	2,000 V_{DC}
▪ Built-in TVS/ESD Protection	
▪ Over Voltage Protection	$\pm 35 V_{DC}$
▪ Power Reversal Protection	
Environment	
▪ Operating Temperature	-10 ~ 50 $^{\circ}C$ (14 ~ 122 $^{\circ}F$)
▪ Storage Temperature	-20 ~ 80 $^{\circ}C$ (-4 ~ 176 $^{\circ}F$)
▪ Operating Humidity	20 ~ 95% RH (non-condensing)
▪ Storage Humidity	0 ~ 95% RH (non-condensing)

ADAM-6050 ADAM-6051 ADAM-6052

18-ch Isolated Digital I/O Modbus TCP Module
14-ch Isolated Digital I/O Modbus TCP Module with 2-ch Counter
16-ch Source-type Isolated Digital I/O Modbus TCP Module

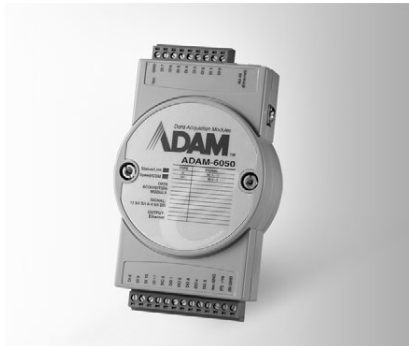

ADAM-6050

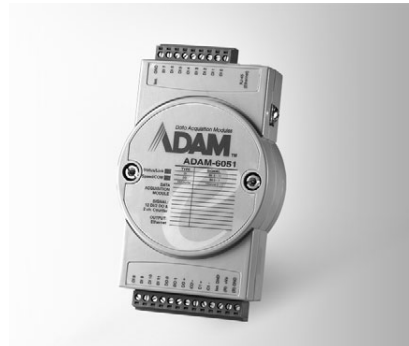

ADAM-6051

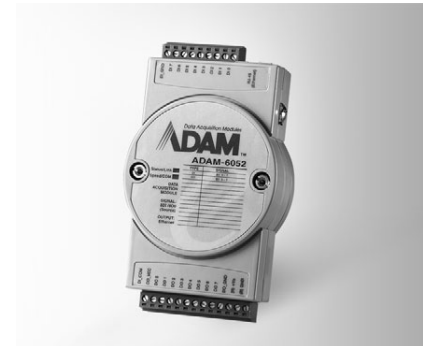

ADAM-6052



Specifications

Digital Input

- Channels 12
- Dry Contact Logic level 0: close to GND
Logic level 1: open
- Wet Contact Logic level 0: 0 ~ 3 V_{DC}
Logic level 1: 10 ~ 30 V_{DC}
- Supports 3 kHz Counter Input (32-bit + 1-bit overflow)
- Keep/Discard Counter Value when Power-off
- Supports 3 kHz Frequency Input
- Supports Inverted DI Status

Digital Output

- Channels 6 (sink type), open collector to 30 V, 100 mA maximum load
- Supports 5 kHz Pulse Output
- Supports High-to-Low and Low-to-High Delay Output

Ordering Information

- ADAM-6050 18-ch Isolated DI/O Modbus TCP Module

Specifications

Digital Input

- Channels 12
- Dry Contact Logic level 0: close to GND
Logic level 1: open
- Wet Contact Logic level 0: 0 ~ 3 V_{DC}
Logic level 1: 10 ~ 30 V_{DC}
- Supports 3 kHz Counter Input (32-bit + 1-bit overflow)
- Keep/Discard Counter Value when Power-off
- Supports 3 kHz Frequency Input
- Supports Inverted DI Status

Counter Input

- Channels 2
- Mode Counter, Frequency
- Keep/Discard Counter Value when Power-off
- Maximum Count 4,294,967,295 (32-bit + 1-bit overflow)
- Input Frequency Frequency Mode: 0.2 ~ 4500 Hz
Counter Mode: 0 ~ 4.5 kHz

Digital Output

- Channels 2 (sink type), open collector to 30 V, 100 mA maximum load
- Supports 5 kHz Pulse Output
- Supports High-to-Low and Low-to-High Delay Output

Ordering Information

- ADAM-6051 16-ch Isolated DI/O with Counter Modbus TCP Module

Specifications

Digital Input

- Channels 8
- Dry Contact Logic level 0: close to GND
Logic level 1: open
- Wet Contact Logic level 0: 0 ~ 3 V_{DC}
Logic level 1: 10 ~ 30 V_{DC}
- Supports 3 kHz Counter Input (32-bit + 1-bit overflow)
- Keep/Discard Counter Value when Power-off
- Supports 3 kHz Frequency Input
- Supports Inverted DI Status

Digital Output

- Channels 8 (Source Type)
- Voltage Range 10 ~ 35 V_{DC}
- Current 1 A (per channel)
- Supports 5 kHz Pulse Output
- Supports High-to-Low and Low-to-High Delay Output
- Supports Over Current Protection

Ordering Information

- ADAM-6052 16-ch Source-type Isolated DI/O Modbus TCP Module

Common Specifications

General

- LAN 10/100Base-T(X)
- Power Consumption 2 W @ 24 V_{DC}
- Connectors 1 x RJ-45 (LAN), Plug-in screw terminal block (I/O and power)
- Watchdog System (1.6 second) and Communication (programmable)

- Power Input 10 ~ 30 V_{DC}
- Supports Peer-to-Peer
- Supports GCL
- Supports Modbus/TCP, TCP/IP, UDP and HTTP Protocol

Protection

- Power Reversal Protection
- Isolation Protection 2,000 V_{DC}

Environment

- Operating Temperature -10 ~ 70° C (14 ~ 158° F)
- Storage Temperature -20 ~ 80° C (-4 ~ 176° F)
- Operating Humidity 20 ~ 95% RH (non-condensing)
- Storage Humidity 0 ~ 95% RH (non-condensing)

ADAM-6060

ADAM-6066

6-ch Digital Input and 6-ch Relay Modbus TCP Module

6-ch Digital Input and 6-ch Power Relay Modbus TCP Module



ADAM-6060

ADAM-6066



Specifications

General

- LAN: 10/100Base-T(X)
- Power Consumption: 2 W @ 24 V_{DC} (ADAM-6060), 2.5 W @ 24 V_{DC} (ADAM-6066)
- Connectors: 1 x RJ-45 (LAN), Plug-in screw terminal block (I/O and power)
- Watchdog Timer: System (1.6 second) and Communication (programmable)
- Power Input: 10 ~ 30 V_{DC}
- Supports Peer-to-Peer
- Supports GCL
- Supports Modbus/TCP, TCP/IP, UDP and HTTP Protocols

Digital Input

- Channels: 6
- Dry Contact: Logic level 0: close to GND, Logic level 1: open
- Wet Contact: Logic level 0: 3 V_{DC}, Logic level 1: 10 ~ 30 V_{DC}
- Supports 3 kHz Counter Input (32-bit + 1-bit overflow)
- Keep/Discard Counter Value when Power-off
- Supports 3 kHz Frequency Input
- Supports Inverted DI Status

Relay Output (Form A)

- Channels: 6
- Contact Rating (Resistive): ADAM-6060: 120 V_{AC} @ 0.5 A, 30 V_{DC} @ 1 A; ADAM-6066: 250 V_{AC} @ 5 A, 30 V_{DC} @ 5 A
- Breakdown Voltage: 500 V_{AC} (50/60 Hz)
- Relay On Time: 7 ms
- Relay Off Time: 3 ms
- Total Switching Time: 10 ms
- Insulation Resistance: 1 GΩ min. at 500 V_{DC}
- Maximum Switching Rate (at rated load): 20 operations/minute
- Supports Pulse Output

Protection

- Isolation Voltage: 2,000 V_{DC}
- Power Reversal Protection

Environment

- Operating Temperature: -10 ~ 70° C (14 ~ 158° F)
- Storage Temperature: -20 ~ 80° C (-4 ~ 176° F)
- Operating Humidity: 20 ~ 95% RH (non-condensing)
- Storage Humidity: 0 ~ 95% RH (non-condensing)

Ordering Information

- ADAM-6060: 6-ch DI and 6-ch Relay Modbus TCP Module
- ADAM-6066: 6-ch DI and 6-ch Power Relay Modbus TCP Module

ADAM-6000 Series Dimensions

Unit: mm

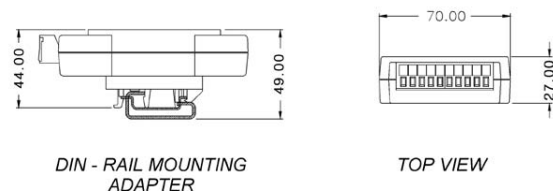
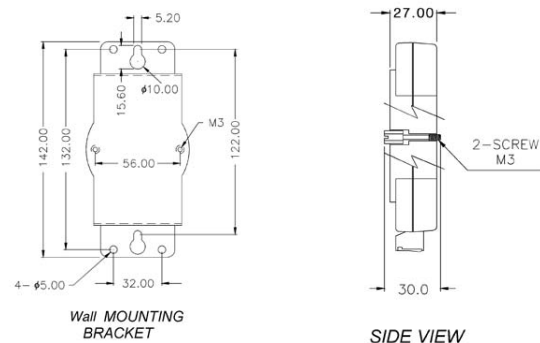
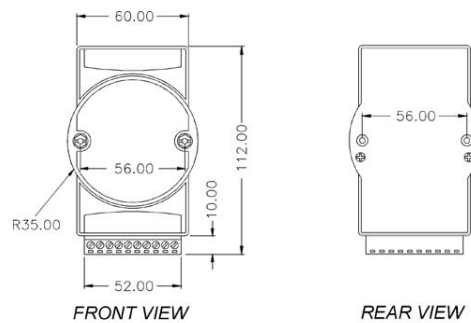

ADAM-6000 Series Common Specifications

General

- Dimension (W x H x D): 70 x 120 x 30 mm
- Enclosure: ABS+PC
- Mounting: DIN 35 rail, stack, wall

- 19 Embedded Controllers
- 20 PC-based Controllers
- 21 PAC
- 22 Motion Control
- 23 RS-485 I/O
- 24 Ethernet I/O
- 25 Building Automation
- 26 Self-service Terminals
- 27 eHome Platforms